



**rabiónconsultancy**

# The SIM and International Roaming

## - Decoupling of Roaming -



**sim**posium  
Global 2013

Raymond Bouwman  
26 June 2013, Amsterdam



# Agenda

- The EU regulation regarding 'Roaming Decoupling'?
- What are the technical scenarios to offer decoupling solutions?
- What is the impact for implementation?
- Economic/Commercial feasibility?
- Point of discussion
- Is roaming decoupling feasible also outside the EU?
- Future SIM developments



# What is stated in the EU regulation about Roaming Decoupling\*?

Article 4 : Separate sale of regulated retail roaming services

Article 5 : Implementation of separate sale of regulated retail roaming services

(Both Articles in current EU Roaming Regulation apply as of 1 July 2014)

Mechanism that enable that no longer the Domestic Provider ('SIM Owner') holds the monopoly on the international roaming service

\* Terminology 'Decoupling' not used in the EU regulation



# What is stated in the EU regulation

## **Article 4 Separate sale of regulated retail roaming services**

1. Domestic providers shall enable their customers to access regulated voice, SMS and data roaming services, provided as a bundle by any alternative roaming provider.....
2. Roaming customers shall have the right to switch roaming provider at any time.....
3. ....The switch to an alternative roaming provider or between roaming providers shall be free of charge for customers and shall be possible under any tariff plan.....
4. Domestic providers shall inform all their roaming customers in a clear, understandable and easily accessible form about the possibility to opt for services .....Customers concluding a contract with a domestic provider for regulated roaming services shall explicitly confirm that they have been informed of such possibility.....



# What is stated in the EU regulation

## Article 5 Implementation of separate sale of regulated retail roaming services

1. Domestic providers shall implement the separate sale of regulated retail roaming services.....Domestic providers shall meet all reasonable requests for access..... access shall be free of charge **and** shall not entail any direct charges to customers.
2. In order to ensure consistent and simultaneous implementation ... the Commission shall...adopt....detailed rules on the information obligations ..... and on a technical solution
3. The technical solution to implement the separate sale of regulated retail roaming services shall meet the following criteria: consumer friendliness, **keeping their existing mobile phone number and while using the same mobile device**, ability to serve all categories of consumer demand,)..... , cost-effectiveness, .....a maximum degree of interoperability, ..... ensuring that roaming by Union customers in third countries or by third country customers in the Union is not impeded, ensuring that the rules on protection of privacy, personal data, security and .....
4. If necessary, the Commission shall give a mandate to a European standardisation body for the adaptation of the relevant standards.....



# What are the technical scenarios to offer decoupling solutions, which ones are chosen?

**In a BEREC consultation BoR (12) 68, June 2012 ROAMING REGULATION, CHOICE OF DECOUPLING METHOD four options studied:**

- Single IMSI
- Single IMSI+
- Dual IMSI
- Local Break OUT (Data only)

**Conclusion (BEREC opinion on article 5 implementing act, 27 september 2012) for July 2014**

- 1) Single IMSI+ and Dual IMSI were considered to complex (for 7/2014)
- 2) Single IMSI and LBO candidates for implementation



# 'Normal' Scenario

Subscription to Domestic Network in Home Country

(Data) Roaming Service determined/controlled by the Home Provider (Price, Product, Qos etc.)

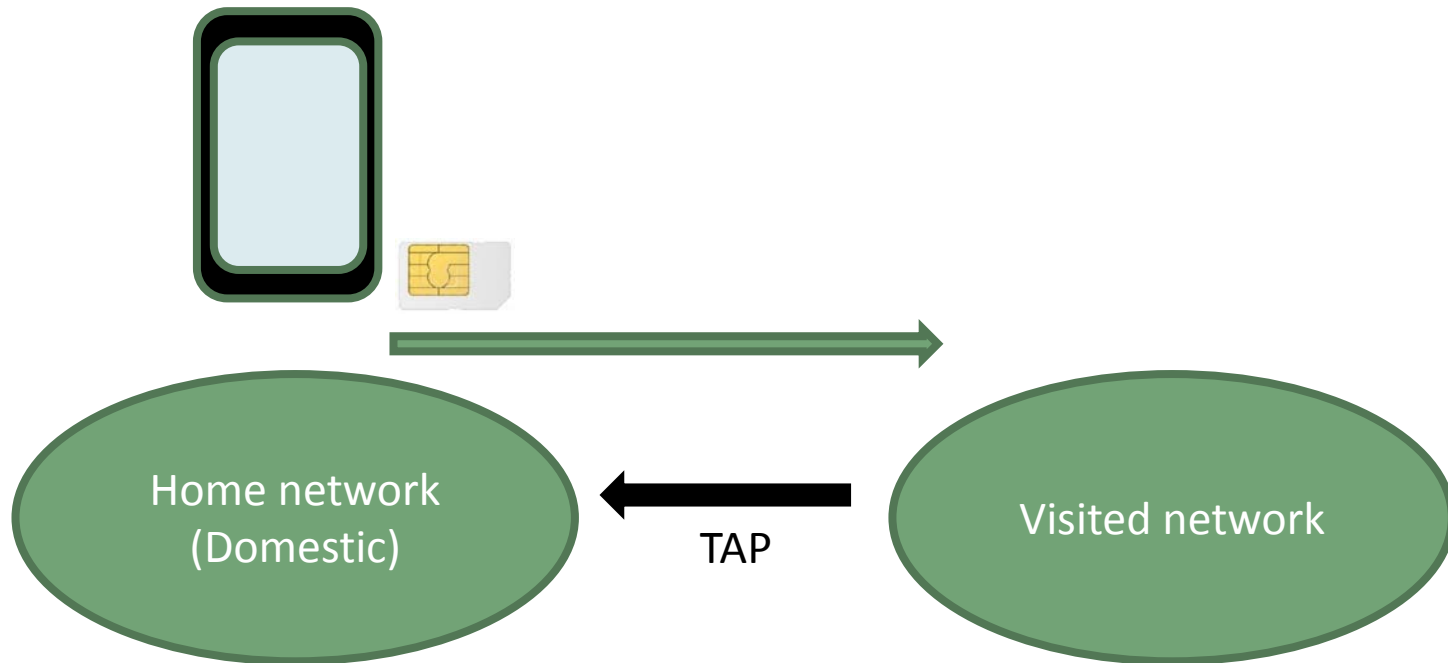

Domestic Provider has the Monopoly on the subscriber roaming services



# 'Roaming Decoupling' (Local Break Out) LBO scenario

Subscription to Network in Home Country

Data Roaming Service provisioning independent from Home Network Provider.

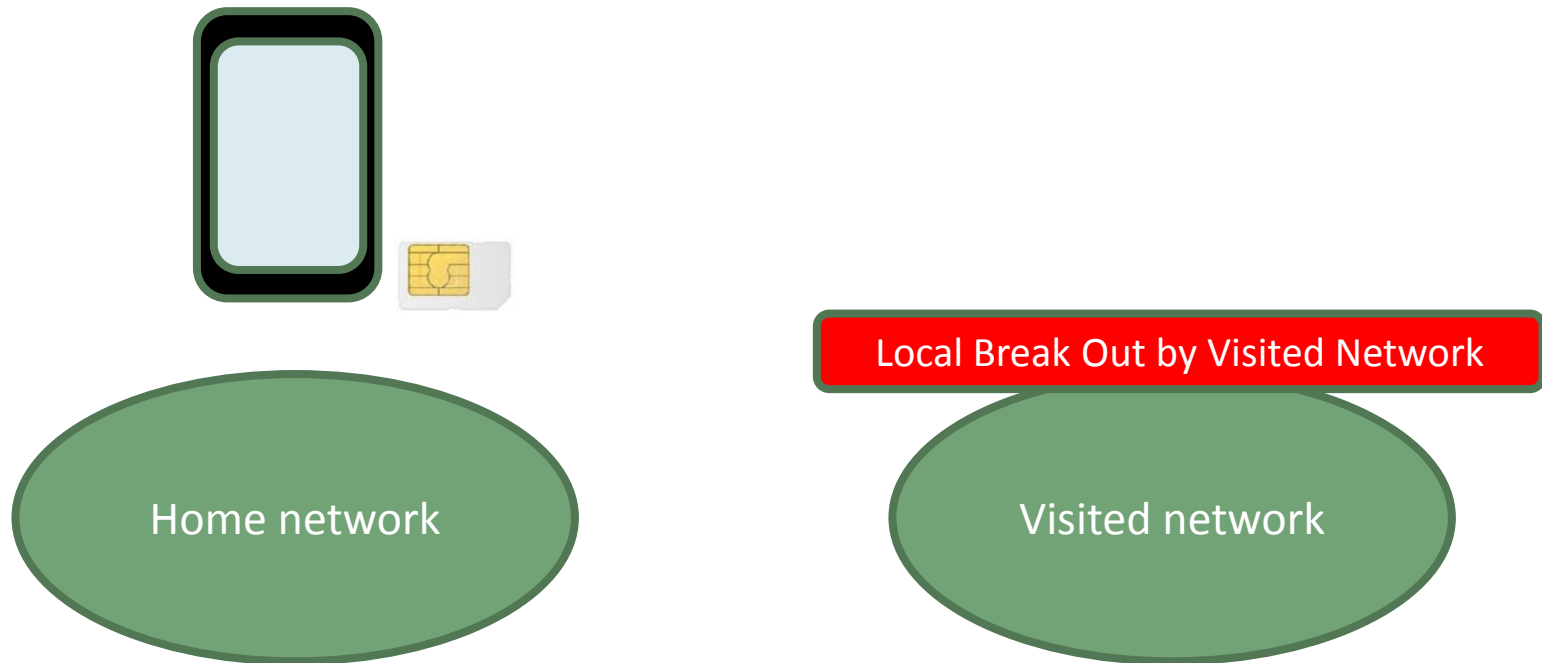

Removes the Monopoly that the Home Network has on the subscriber roaming (EU roaming Regulation, July 2014)





# How does LBO work

- Customer signs up with LBO provider (up front before roaming, or while roaming)
- Payment depending on the LBO offer (could be 'WiFi-like')
- Home network provides 'LBO APN' in the roaming profile ('EUinternet')
- SMS and Voice, Voicemail unaffected in the Visited Network
- Security based on the Home network system
- SoR and Manual Selection issues
- Restoration of APN required when no longer the LBO is used
- No (home network) support for data services (e.g. Blackberry, content, VPNs etc.)
- No Data TAP/CDR to Home network
- New Notification/Interface needed between Visited Network/LBO and Home network (to start/stop the service)
- Customer Can have several LBO's at the same time (in different countries or from different providers) and irrespective of the Single IMSI Alternative Roaming Provider.



# LBO solution

## PDP profile

- VPLMN Access Allowed = ON (allows local roaming, where Home roaming is/was commonly applied in Mobile networks)
- APN = 'EUinternet'

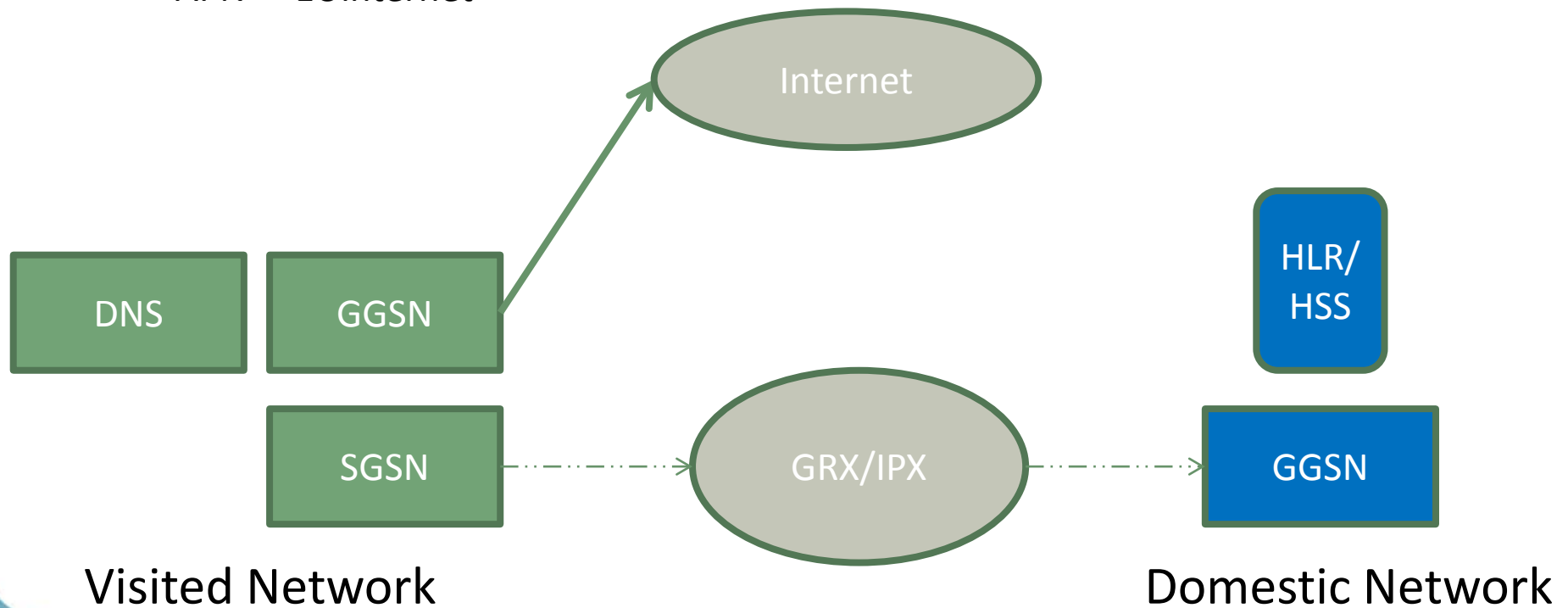



# Mobile Communication

## 'Roaming Decoupling' (Single IMSI)

Subscription to Network in Home Country has Flexibility to sign-up with a Service Provider Independent of the Home Network – pure Wholesale model (although shift from the current all-or-none wholesale model)

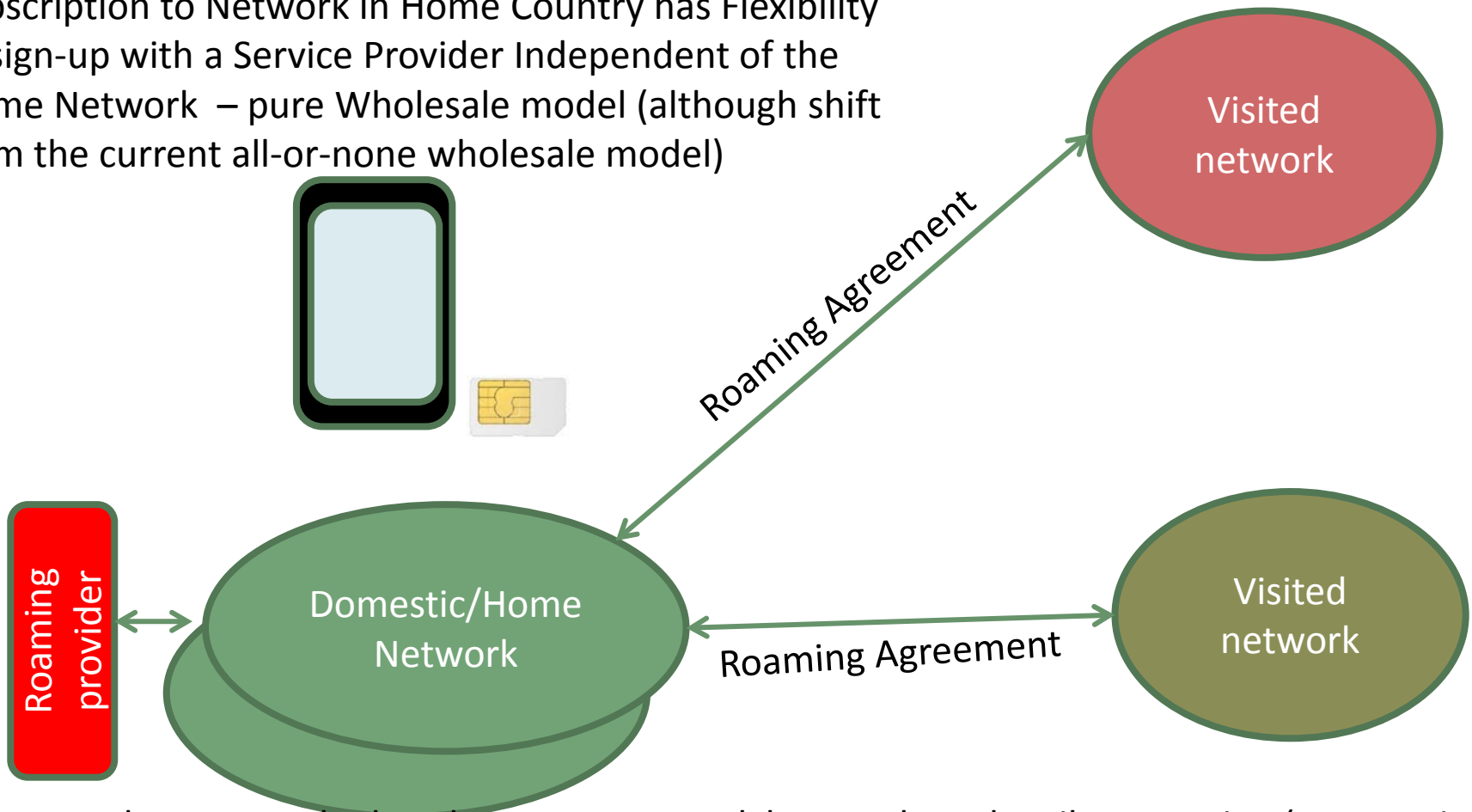

Removes the Monopoly that the Home Network has on the subscriber roaming (EU roaming Regulation, July 2014)



# Who does it work

- Pure wholesale solution, but split between the domestic provider and an alternative roaming provider
- Roaming Service and implementation as such unaffected
- Only one Alternative Roaming Provider at the time
- Camel/Diameter interfaces for Charging, BSP Cost Control
- CDR exchange, Provisioning interfaces in a MVNO-like manner



# Overview

- + Single IMSI : Pure wholesale for sms, voice, data roaming
- Single IMSI+ : Single IMSI model but including SoR to a visited network of choice
- Dual IMSI : two or more (U)SIM applications on one UICC (individually managed)
- + Local Break Out : Data only to an ARP



# Economic/Commercial feasibility?

- LBO may be complicated for customers (settings, APNs, manual network selection, various LBO's in parallel)
- LBO not a mass service (although 'wifi-like')?
- Single IMSI is the easier concept (like a carrier select), addition to the MVNO portfolio
- Single IMSI may be just temporary feasible as long as there is margin between regulated retail and wholesale rates
- Announcement that roaming rates in EU will disappear in due time (2014-1015), will impact in particular feasibility of the single IMSI service.
- LBO in particular for LTE may be opportunity (i.p. while no LTE international roaming is available)



# Interface Single IMSI

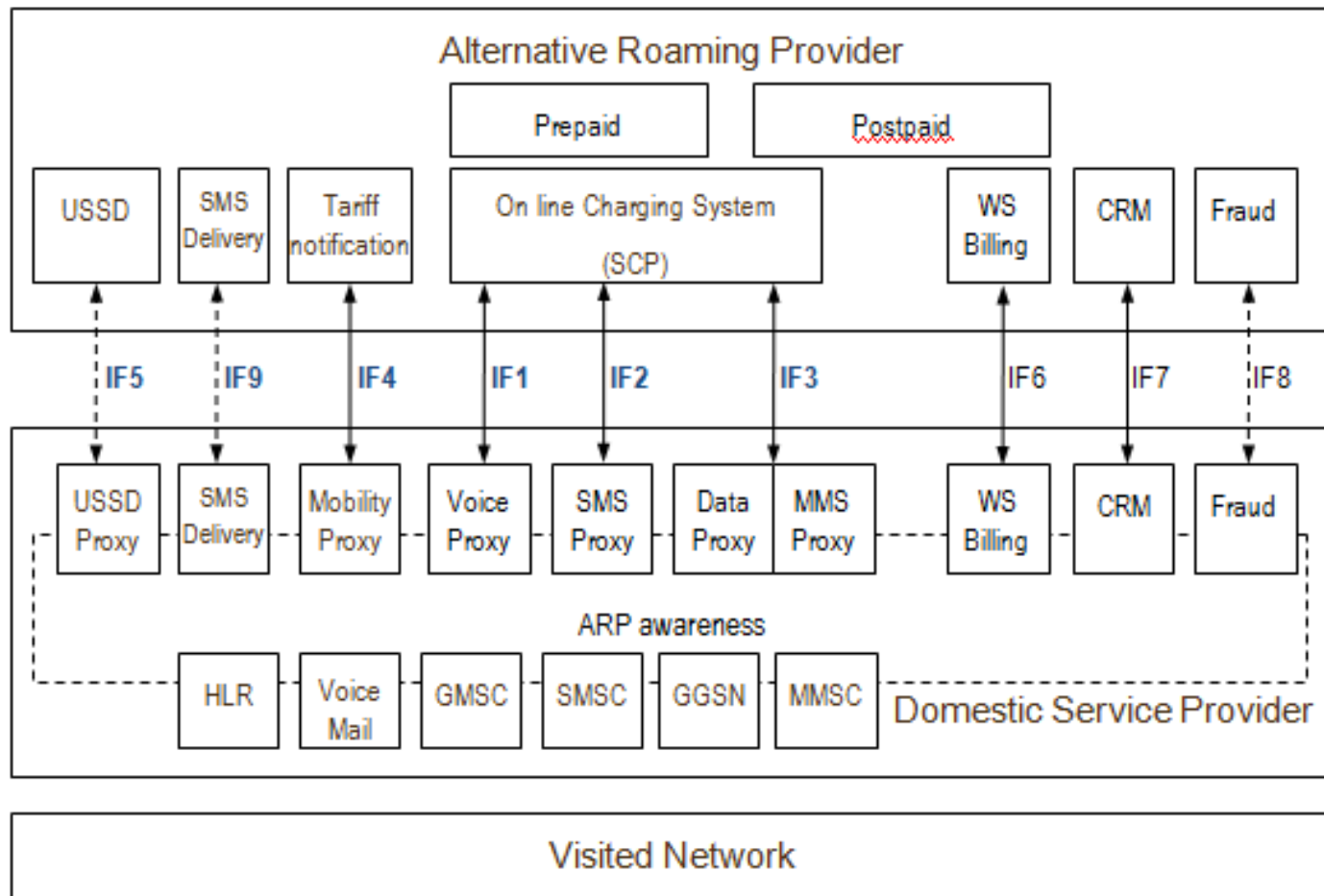



# LBO interfaces

Only IF2 is new, IF1 and IF3 are existing

IF1 will make use of the EU APN and VPLMN allowed parameter

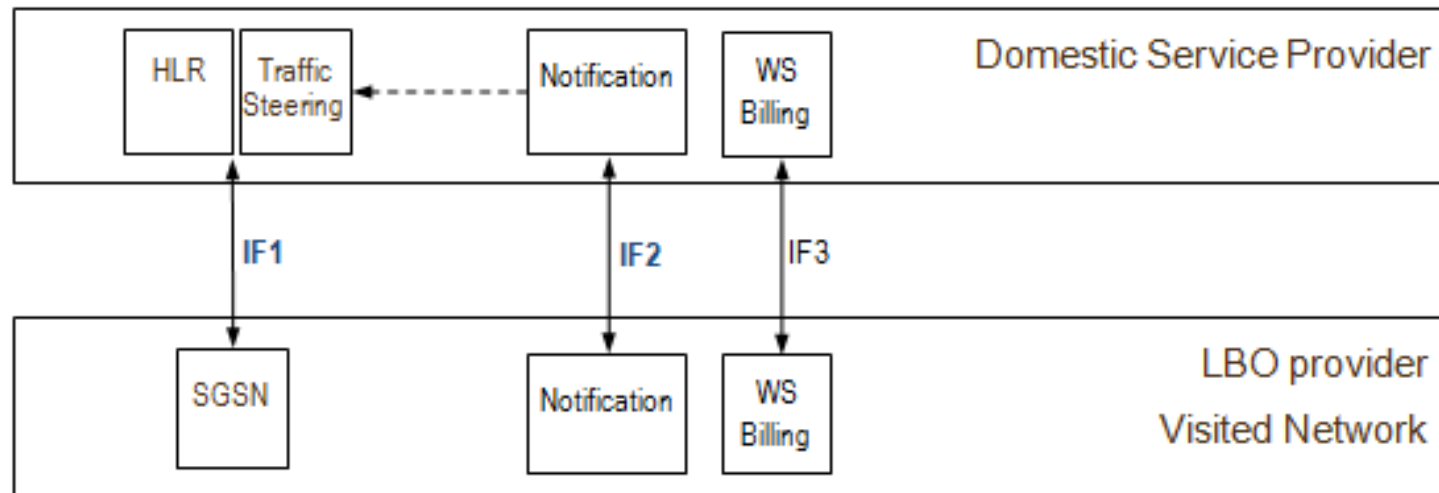

Figure 9 – LBO interface definition





## Risks for existing (roaming) providers

- Loss of roaming volume and revenue
- Further pressure on roaming retail prices
- Increased (roaming) competition
- Access has to be granted to (all reasonable requests from) ARPs and LBOs
- Implementation Cost



# EU reaches preliminary deal on future-proof roaming solution for mobile phone users (march 2012)

**Current and new retail price caps (excluding VAT)**

	Current	1 July 2012	1 July 2013	1 July 2014
Data (per MB)	None	70 cents	45 cents	20 cents
Voice-calls made (per minute)	35 cents	29 cents	24 cents	19 cents
Voice-calls received (per minute)	11 cents	8 cents	7 cents	5 cents
SMS (per SMS)	11 cents	9 cents	8 cents	6 cents

**Current and new wholesale price caps (on prices operators charge each other):**

	Current	1 July 2012	1 July 2013	1 July 2014
Data (per MB)	50 cents	25 cents	15 cents	5 cents
Voice (per minute)	18 cents	14 cents	10 cents	5 cents
SMS (per SMS)	4 cents	3 cents	2 cents	2 cents



# Opportunities for whom (LBO)?

- Many (70-80%) of EU customer do not use Data Roaming currently
- Customers get more and more 'savvy' to avoid traditional roaming, and to choose and select Wifi vs Mobile, and choosing price-efficient applications whenever needed (Skype, OTT-VoIP). Customers cannot without Data!
- Visited networks can decide to turn Data Roaming revenues into LBO revenues. If customers choose for LBO then voice and SMS outbound roaming will remain, or use to attract new customers that would normally be unreachable
- Operator groups in advantage as they can offer an LBO package for a group of countries?
- For the LBO provider the incremental cost for LBO is low, allowing for rate plans at the level of the local pricing (instead of roaming pricing) but at the risk of jeopardizing the (inbound) roaming revenue



# Opportunities for whom (Single IMSI)?

- Existing MVNO/service Providers to extend their business, or may be a new MVNO niche
- Existing roaming providers ('plastic roaming')
- MVNO group in several countries to mirror offers in various countries
- Sufficient margin between retail roaming pricing and wholesale roaming pricing required



# Discussion

- Roaming Decoupling may be of value to further enhance change and innovation in an industry that has become 'traditional' and
- Traditional Telecom parties not 'over-enthusiastic'
- Probably not a service for the mass, but to be targeted at specific groups, and/or by specific resellers/providers.
- EU single Market, and abolishing of roaming rates?



Is roaming decoupling feasible also outside the EU (unregulated roaming areas)?

- Technically similar solutions may apply
- Harmonized APN as in the EU (regional or worldwide)
- GSMA support needed...
- Wholesale/MVNO support in markets



# Traditional Roaming in decline

- SMS, roaming and voice revenues are decreasing
- Wifi development becoming more and more important, and putting pressure on traditional (GSM) roaming
- 'Voice' less important if data is widely available
- In EU: Future Single Market will 'kill' roaming revenues
- Also outside Europe roaming regulation/solutions are developing (LA, GCC)
- LTE will make the roaming portfolio more complicated
- Spectrum issue LTE



# How was Data roaming designed

Domestic Network

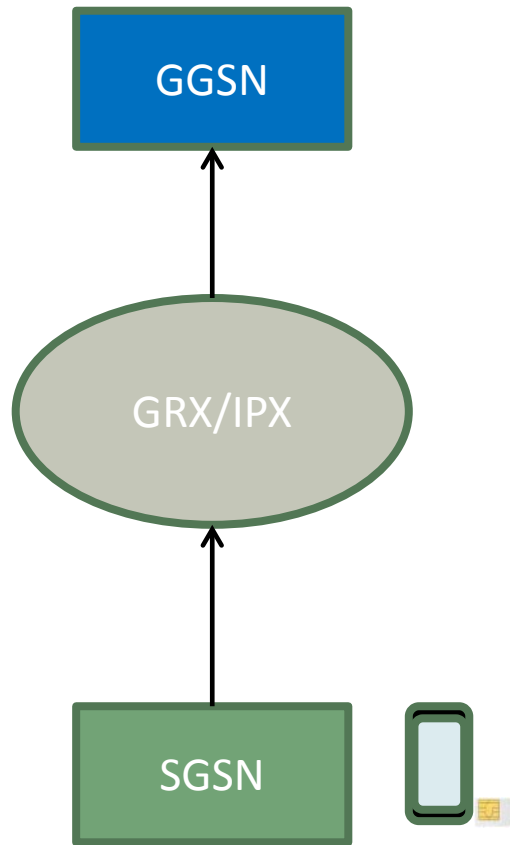

Visited Network

## Home Roaming Scenario

- Domestic network to manage billing and charging (both postpaid and prepaid)
- Independent from the visited network
- Ability to offer home-based service (e.g. corporate connectivity, additional security)
- Content control ( e.g. in case of Blackberry)
- QoS management ( incl Bill Shock Prevention)
- No 'contact' between customer and Visited Network

Roaming Agreements needed!





# LBO LTE scenario

Domestic Network

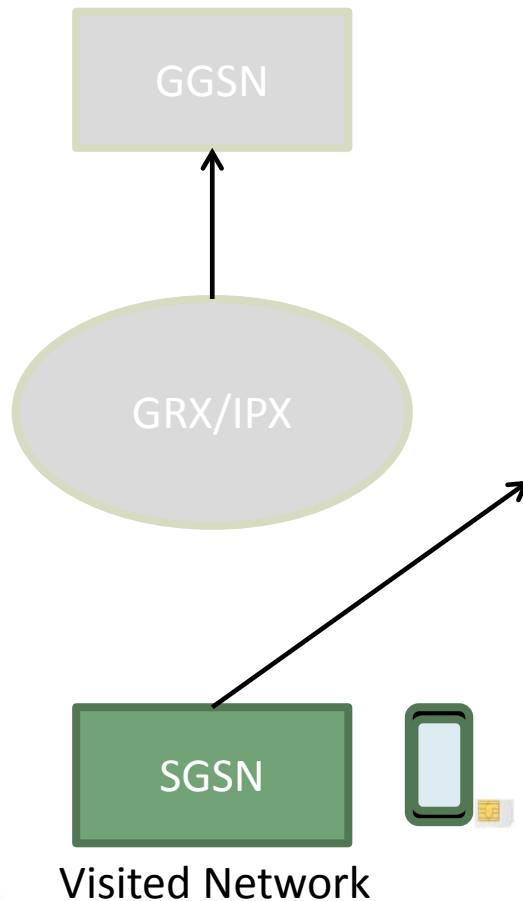

IF

- No (or few) LTE roaming agreements
- No upcharge for roaming service allowed
- Customers primarily use OTT services (e.g. whatsapp, 3rdP VoIP etc.)
- Limited role for VoLTE?

THEN

- Visited network takes the control over service and customer.
- Home network bypassed (except for SMS and CS-Voice)
- LBO LTE is the alternative and challenger scenario fNo LTE international roaming needed



# SIM and other developments...

- Dual/Multi IMSI solutions and remote flexible configuration of profiles (would allow full and flexible Break-out)
- Remote configuration of Security parameters
- Apps to support the (LBO) customer
- Could serve services (costs decrease) that need international access ( e.g. e-call, mobility services, automotive)



**rabiónconsultancy**

Questions and Information:

Rabión Consultancy B.V.

Contactperson: Raymond Bouwman

Koningsweg 1B

7255 KR Hengelo (Gld)

the Netherlands

Office: +31 182 391975

Mob: + 31 650287899

[office@rabion.com](mailto:office@rabion.com) or [raymond.bouwman@rabion.com](mailto:raymond.bouwman@rabion.com)

[www.rabion.com](http://www.rabion.com)